

What is Air-Lock?

Air-Lock protects oil drums against contaminant ingress during storage. Air-Lock's patented design prevents contamination by increasing the headspace air pressure, which acts as a barrier against contaminants. Air-Lock also features a yellow fluorescent indicator to indicate a good seal and that pressure is maintained.

Features

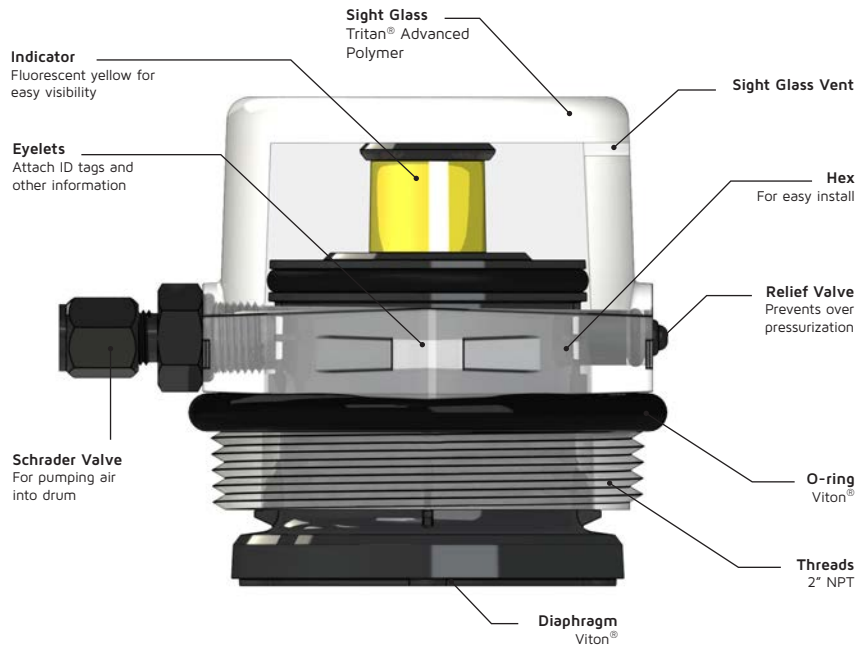

Warnings and Disclaimers

- For use on 55-gallon steel drums that are in good condition and capable of holding air pressure.
- Do not remove the drum lid, bung plugs, or Air-Lock while the drum is sealed and pressurized. There may still be pressure even though the Indicator is not visible.
- Do not use Air-Lock if ambient temperatures are greater than 200°F (93°C) or if ambient temperature fluctuations are greater than 75°F (24°C).
- Do not use Air-Lock with a drum desiccant breather, pump, or filter cart.
- Do not expose Air-Lock to chemicals not compatible with Tritan® or Viton®.
- Do not clean Air-Lock with high-pressure water.
- Be careful not to damage or puncture the Diaphragm at the bottom of Air-Lock.
- Do not plug or block the relief valve or sight glass vent.
- Visit Luneta.com for more details.

Luneta Air-Lock®

Part Number

AIR-LOCK

LUNETA

SMART PRODUCTS • RELIABLE MACHINES



Luneta LLC | 888.742.2021 | Luneta.com
Sales@Luneta.com

Installation Instructions

- Steel drums typically have two openings (bung holes), one with a 2" plug and another with a ¾" plug.
- To install Air-Lock, remove the existing 2" bung plug and replace it with Air-Lock. Do not use thread sealing tape or other sealers on the Air-Lock threads.
- Tighten Air-Lock by hand or wrench until the O-ring is fully compressed. Do not tighten more than 12 ft-lbs. Do not use the schrader valve as leverage.
- Check to ensure the ¾" bung plug is tight and sealed.
- Attach an air compressor to the schrader valve and pressurize the drum. The air compressor regulator must be set to 100 psi or less.
- The yellow fluorescent indicator will begin to travel and become visible when the headspace pressure reaches 1.0 psi. The indicator will stop and reach its limit at 1.5 psi.
- STOP pressurizing five seconds after the indicator stops rising, or when the headspace pressure is around 2.5 psi.
- As a safety measure, the relief valve will open at 4 psi. Do not use the relief valve as a stopping point.
- Check for audible leaks. If you hear escaping air, follow the air leak instructions below.
- Wait a few minutes to check and ensure the indicator doesn't drop back down. If the indicator remains visible, the drum is now sealed and protected from contamination.
- If the indicator drops back down, see the air leak instructions below.
- Attach the included drum lid decal to the drum lid next to the Air-Lock for future reference.

Solving Air Leaks

If the indicator drops back down or you hear escaping air, there is an air leak. If the leak location is unknown, use soapy water and look for bubbles. Below is a list of possible leak locations:

- Relief Valve. Wait several minutes until the pressure drops below the reseal pressure of the valve, or 3 psi.
- O-ring. Tighten Air-Lock by hand or with a wrench. Do not tighten more than 12 ft-lbs. Do not use the schrader valve as leverage. If this doesn't work, relieve the pressure, remove Air-Lock, and inspect the O-ring and sealing surface.
- Schrader Valve. Tighten the valve with a 13mm wrench. Do not tighten more than 18 in-lbs.
- ¾" Bung Plug. Tighten the plug. If this doesn't work, relieve the pressure, remove the plug, and inspect the plug gasket and sealing surface.
- Open Head Drum Seal. Tighten the bolt or lever lock ring closure that secures the lid to the barrel. If this doesn't work, relieve the pressure, remove the drum lid, and inspect the gasket and sealing surface.
- Sight Glass Vent. Contact Luneta for further instructions.

How to Use Air-Lock

- Check Air-Lock daily to ensure the drum remains sealed against outside contaminants.
- If the yellow indicator is visible, the drum is sealed and protected.
- If the yellow indicator is NOT visible, the drum is not sealed, and action must be taken to increase the pressure and/or investigate why the pressure dropped.

NOT SEALED



SEALED

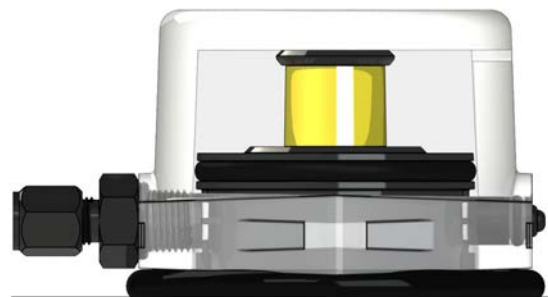

Removal Instructions

- Air-Lock will need to be removed to access the oil in the drum.
- Never remove Air-Lock while sealed and pressurized. There may still be pressure even though the indicator is not visible.
- To relieve air pressure, rotate Air-Lock 1/2 turn counterclockwise and wait until the sound of escaping air stops. Only then is it safe to remove Air-Lock.